

Casing Scraper

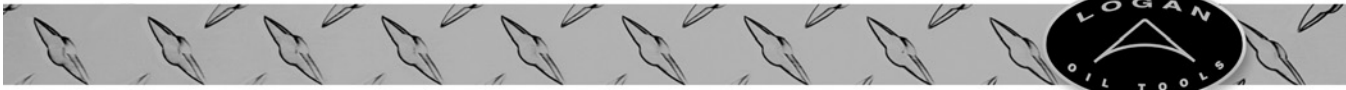

Contents

Logan Casing Scraper

- Overview..... 2
- Uses 2
- Construction 2
- Operation..... 2
- Maintenance..... 2
- Disassembly 2
- Assembly 3
- Tool Illustration..... 3
- Parts List..... 5
- Recommended Tightening Torques 5



Logan Casing Scraper

OVERVIEW

Obstruction-free casing is critical for the efficient operation of many downhole tools during drilling, fishing, completion, or wireline jobs. The Logan Casing Scraper removes rust, scale, cement, mud, bullets, paraffin, perforation burrs and other obstructions or foreign material from the inside walls of casing. Logan Casing Scrapers are available to condition pipe ranging from 4-1/2 to 13-3/8 inches O.D.

USES

Maintaining a clean casing I.D. is important when operating drilling, fishing or wireline tools. Likewise, packers, patches, spears, and similar tools require clean surfaces to grip. Obstructions on casing walls frequently cause these tools to fail or become difficult to operate.

The Logan Casing Scraper removes deposits, burrs, and irregularities from casing that might cause trouble during the operation of packers or other close-tolerance equipment.

Some of the main uses of the Logan Casing Scraper are to:

1. Clean out paraffin, hardened cement, and mud.
2. Remove burrs from perforations.
3. Remove imbedded bullets from casing.
4. Remove burrs and nicks caused by bits or fishing tools.
5. Remove tight spots in casing caused by dents from tool mishandling.

CONSTRUCTION

All Logan Casing scrapers are constructed with a single (1) scraper body, a (1) blade retainer, six (6) scraper blades with springs, two (2) retainer rings, a top and bottom retainer ring nut, and two (2) retainer ring set screws.

The one-piece scraper body is rugged and easy to maintain. The splined body locks each blade into an integral part of the body to insure absolute safety and security.

The Logan Casing Scraper has two (2) sets of three (3) blades. Each blade is constructed from high quality cast steel for excellent scraping characteristics and long-lasting durability. These six (6) scraper blades are designed to scrape over 360° of surface area. The scraper blades are designed with a long taper for passing through casing connections with minimal chance of hanging up. Each blade has a recessed pocket that holds the springs between the blade and the scraper body. These springs keep the blades firmly pressed against the pipe and allow the blades to compress and depress during scraping operations.

The blades and springs are held in place on the scraper body with the blade retainer and two (2) retainer rings. A top and bottom retainer ring nut secures the retainer rings in position.

Two (2) retainer nut set screws are used as a safety precaution to keep the top and bottom retainer rings locked in position. The top retainer ring nut is left-hand to prevent back off downhole during right-hand rotation should the set screws loosen during operation.

OPERATION

The Logan Casing Scraper is normally made up to the work string with a drill bit attached to the bottom connection. Simply run the scraper into the casing or tubing using rotation or spudding to clean the inside wall of the pipe.

MAINTENANCE

Good maintenance will ensure maximum life of the Logan Casing Scraper and prevent misruns. The tool should be completely disassembled and thoroughly cleaned after each use. Worn or damaged parts should be replaced during disassembly/assembly.

DISASSEMBLY

All disassembly and repairs should be conducted in a clean, well-equipped shop.

1. Place the Casing Scraper in a suitable vise. Clamp on either the box or pin end fishing neck.
2. With a suitable wrench, remove the two (2) set screws from the top and bottom retainer ring nuts.

CAUTION: The top retainer ring nut has a left-hand thread.

3. Remove the top retainer ring nut with a suitable wrench.

NOTE: The top retainer ring nut is the nut that is on the pin end of the Casing Scraper. Stenciling on the nut indicates that it has a left-hand thread.



Logan Casing Scraper

4. Arrange the Casing Scraper so two (2) of the blades are located on the bottom of the tool. With the aid of a looped strap and a suitable lifting device, such as an overhead crane or the arm of a forklift, pick up the strap to compress the blades and springs located on the bottom. Place a hand on the remaining top blade and slide the retainer ring back away from the blades.
5. Remove the top blade being careful not to lose the springs under the blade. Carefully lower the looped strap that is holding the two (2) bottom blades in place. Be careful not to lose the springs as the bottom blades are removed.
6. Remove the bottom retainer ring nut from the body.

NOTE: The bottom retainer ring nut has right-hand threads.

7. Repeat steps 4 and 5 to remove the other three (3) blades.

Thoroughly clean and inspect all parts. Replace any collapsed springs or those that have a weak recoil. Replace any blades that are chipped or severely worn. Tong and wrench marks should be filed smooth.

ASSEMBLY

The Logan Casing Scraper is easily assembled using standard shop tools. No special tools are required.

Make sure all parts have been thoroughly cleaned and inspected prior to assembly. Have high quality thread compound and thick grease on hand.

1. Place the Casing Scraper body in a vise. Position the body so that two of the pockets for the blades are on the bottom. Clamp near one end.

2. Apply grease to the springs.

NOTE: The grease will help the springs stay in place when they are inserted into the blades.

3. Place a blade with springs into the pocket on the body by slipping the lip of the blade under the blade retainer.
4. Slip a second blade with springs into the other pocket on the bottom. Tension on the looped strap may need to be adjusted to accomplish this. Pull tension on the looped strap with the lifting device until the blades and springs are compressed.
5. Place the third blade with spring in the pocket on top.
6. Grease the inside of the retainer ring and slide it over the end of the scraper blades. The top blade may have to be compressed slightly to position the ring in place.
7. Dope the threads on the body for the retainer ring nut with thread compound. Install the retainer ring nut and tighten sufficiently.

NOTE: Remember, the top retainer ring nut has left-hand threads and the bottom retainer ring nut has right-hand threads.

8. Repeat steps 2 through 7 for the other end of the Casing Scraper body.
9. Install the two (2) set screws with thread compound and tighten.

The Logan Casing Scraper is now ready for use.



Logan Casing Scraper

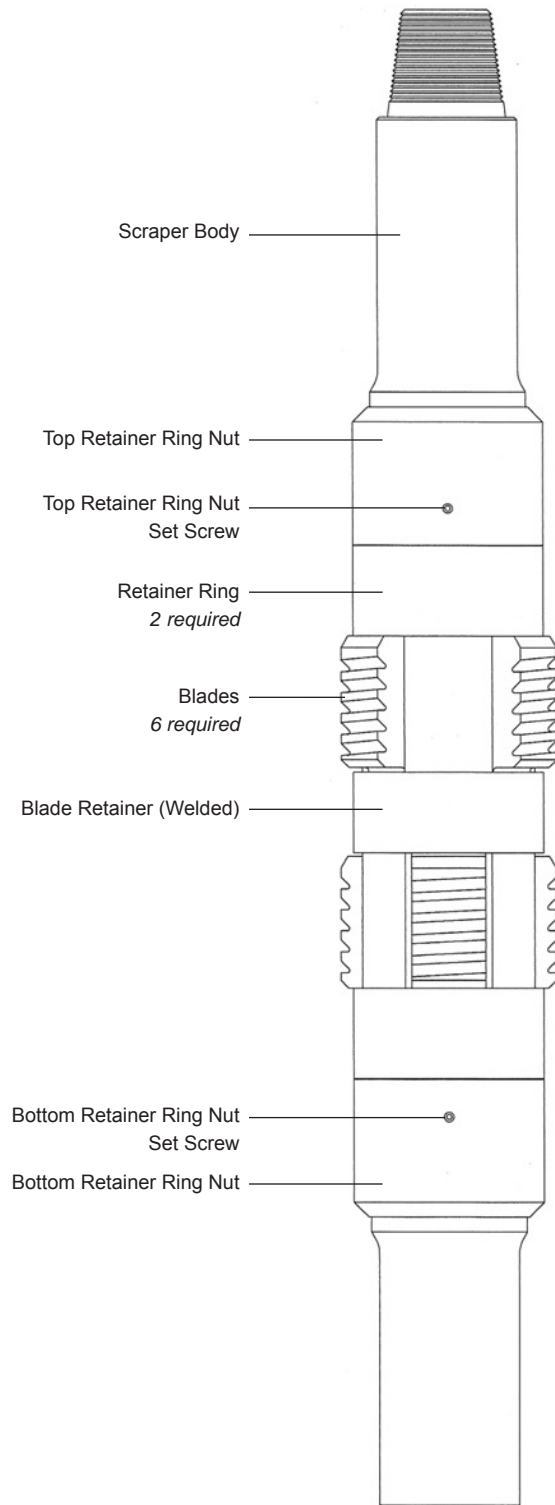



Logan Casing Scraper

SIZE TO SCRAPE (O.D.)		4-1/2	5-1/2	7	9-5/8	10-3/4	13-3/8	
WEIGHT (LBS)		9.5 to 15.1 5 13.0 to 26.7	14.0 to 23.0	17.0 to 38.0	32.2 to 64.9	32.75 to 73.2	48.0 to 98.0	
CONNECTION		2-3/8 API Reg	2-7/8 API Reg	3-1/2 API Reg	4-1/2 API Reg	6-5/8 API Reg	6-5/8 API Reg	
TOOL O.D.		3-5/8	4-1/2	5-3/8	7-1/2	8-3/4	11	
COMPLETE ASSEMBLY	Logan Part No.	508-361	508-450	508-538	508-750	508-875	508-1100	
MANDREL	Logan Part No.	AX800	AX10011	AX1002	AX1003	AX1004	AX1005	
BLADE	Logan Part No.	AX2000	AX2001	AX2002	AX2003	AX2004	AX2005	
	No. Req'd	6	6	6	6	8	6	
SPRING	Logan Part No.	AX802	AX40011	AX4000	AX4003	AX40013	AX4005	
	No. Req'd	18	18	30	30	24	30	
TOP RETAINER RING NUT (LEFT-HAND THREAD)	Logan Part No.	AX7000	AX7001	AX7002	AX7003	AX7004	AX7005	
BOTTOM RETAINER RING NUT (RIGHT-HAND THREAD)	Logan Part No.	AX8000	AX8001	AX8002	AX8003	AX8004	AX8005	
RETAINER RING	Logan Part No.	AX9000	AX9001	AX9002	AX9003	AX9004	AX9005	
	No. Req'd	2	2	2	2	2	2	
SET SCREW	Logan Part No.	P12004	P12004	AX10002	AX10002	AX10002	AX10004	
	No. Req'd	2	2	2	2	2	2	

OPTIONAL DRESS FOR SIZE (O.D.)		...	5-3/4	7-5/8	
WEIGHT (LBS)		...	14 to 24.4	24 to 47.1	
BLADE	Logan Part No.	...	AX30012	AX3002	
	No. Req'd	...	6	6	
SPRING	Logan Part No.	...	AX40012	AX4000	
	No. Req'd	...	18	30	

OPTIONAL DRESS FOR SIZE (O.D.)		...	6-5/8	
WEIGHT (LBS)		...	17 to 24	
BLADE	Logan Part No.	...	AX30013	
	No. Req'd	...	6	
SPRING	Logan Part No.	...	AX40013	
	No. Req'd	...	18	

Logan Oil Tools reserves the right to change or discontinue designs and/or prices without notice.

When ordering, please specify:

- (1) Name and number of assembly or part
- (2) Size and weight of casing

Recommended Spare Parts:

- (1) 1 set of Blades for each size casing

RECOMMENDED TIGHTENING TORQUES

COMPLETE ASSEMBLY	Logan Part No.	508-361	508-450	508-538	508-750	508-875	508-1100	
TOOL O.D. (IN)		3-5/8	4-1/2	5-3/8	7-1/2	8-3/4	11	
CASING SIZE (IN)		4-1/2 to 5	5-1/2 to 6-5/8	7 to 7-5/8	9-5/8	...	13-3/8	
TORQUE (FT-LBS)		350	450	550	750	875	1,100	

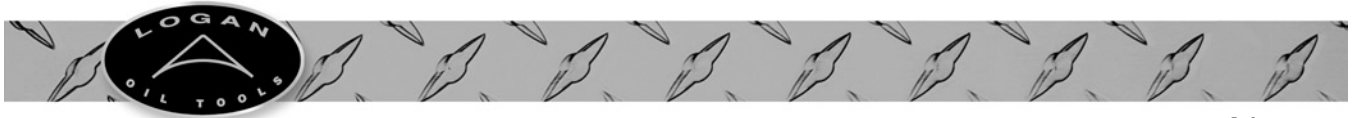

Notes

HEADQUARTERS

11006 Lucerne Street
Houston, TX 77016
Tel: (281) 219-6613
Fax: (281) 219-6638

sales@loganoiltools.com

UNITED STATES

California

3155 Pegasus
Bakersfield, CA 93308
Tel: (661) 387-1449
Fax: (661) 387-1624

Louisiana

103 Bluffwood Drive
Broussard, LA 70518
Tel: (337) 839-2331
Fax: (337) 839-2334

118 Common Court
Houma, LA 70360
Tel: (985) 868-7333
Fax: (985) 868-7007

Oklahoma

424 South Eagle Lane
Oklahoma City, OK 73128
Tel: (405) 782-0625
Fax: (405) 782-0760

Mississippi

6 Donald Drive
Laurel, MS 39440
Tel: (601) 649-0636
Fax: (601) 649-6909

Texas

101 Commerce Street
Alice, TX 78332
Tel: (361) 396-0139
Fax: (361) 396-0112

1305 Energy Drive
Kilgore, TX 75662
Tel: (903) 984-6700
Fax: (903) 984-6755

1617 South Viceroy
Odessa, TX 79763
Tel: (432) 580-7414
Fax: (432) 580-7656

Utah

1369 South 1100 East
Vernal, UT 84078
Tel: (435) 781-2856
Fax: (435) 781-2858

STOCKING DISTRIBUTORS

Canada

Lee Oilfield Fishing Tools Ltd.
4604 Eleniak Road NW
Edmonton, AB T6B2S1
Canada
Tel: (780) 440-6705
Fax: (780) 463-5570

Dubai

Woodhouse International
P.O. Box 23724
Dubai, UAE
Tel: 971-4-347-2300
Fax: 971-4-347-4642

Scotland

Smith Services, HE Group
Howe Moss Avenue
Dyce, Aberdeen
Scotland AB21 OGP
Tel: 44-1224-770707
Fax: 44-1224-724182



www.loganoiltools.com