

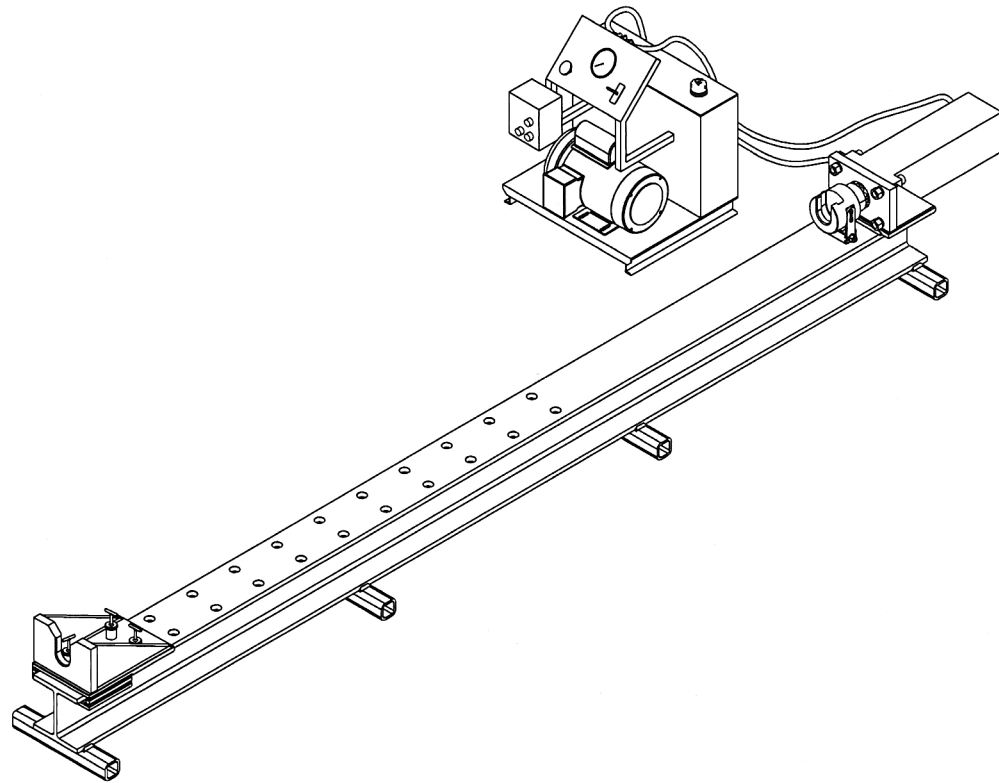

Jar Tester



Overview

The Logan Jar Tester is a versatile machine for setting, checking, or testing pull loads of a variety of tools with outer diameters up to 11 inches. The Jar Tester is capable of exerting tension or compression loads in a controlled manner. The Logan Jar Tester provides an effective and accurate means for shop testing hydraulic jars; setting and checking pull loads of mechanical rotary jars, safety joints, bumper subs, and other similar tools; and testing formation tools. It is especially useful when many such tools must be maintained on a recurring basis.

Construction

The Logan Jar Tester is composed of two basic components: a frame and a prime mover. A pull plate and cross head cradle the tool to be tested. The cross head is attached to a hydraulic cylinder that supplies the tensile or compressive load. The prime mover, which is also referred to as the power-pak, is an electric, motor-driven hydraulic power supply. It is composed of a hydraulic pump, an electric motor, a hydraulic reservoir, a start/stop switch, a pressure gauge, a filter, and appropriate valve fittings to properly operate and maintain the system.

All components of the Logan Jar Tester are manufactured from high-grade materials. All main load bearing members are made from selected heat-treated alloy steel for maximum strength and durability.

All Logan Jar Testers are completely assembled and tested before shipment. The unit requires very little maintenance. However, usual wear parts must be occasionally replaced.

When ordering, please specify:

(1) Complete Assembly part number: **900-002**